

REGENTONNE, 500 L TONNEAU DE PLUIE, 500 L

Art.-Nr. / No. d'art. 241136



BEDIENUNGSANLEITUNG MODE D'EMPLOI

CH-IMPORTEUR: MAX TRADA AG · CHURERSTRASSE 82 · CH-8808 PFÄFFIKON SZ

MONTAGE

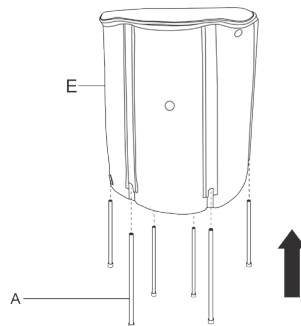
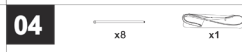
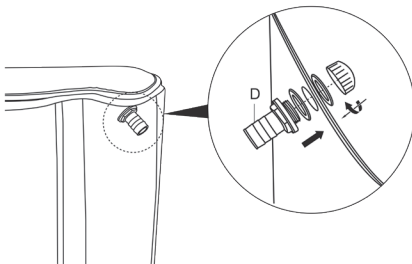
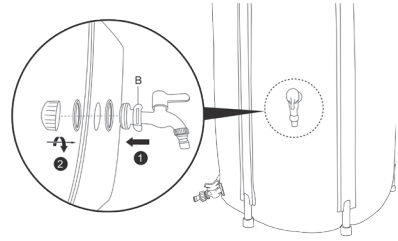
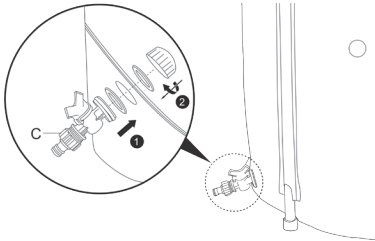
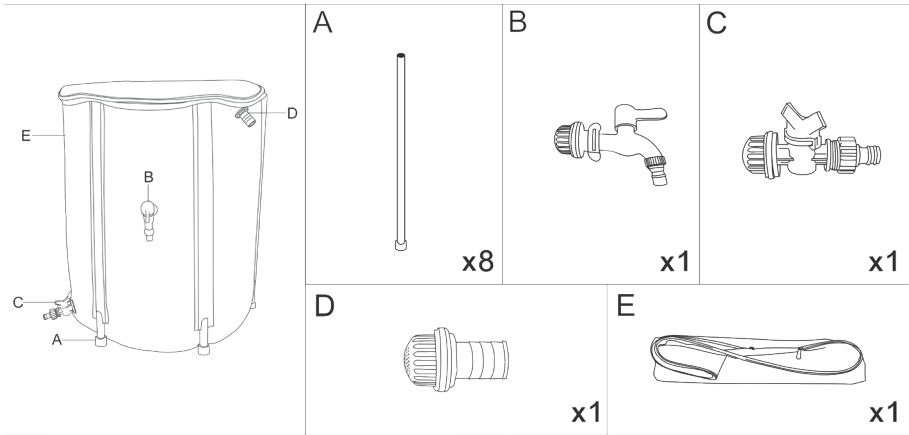

MONTAGE

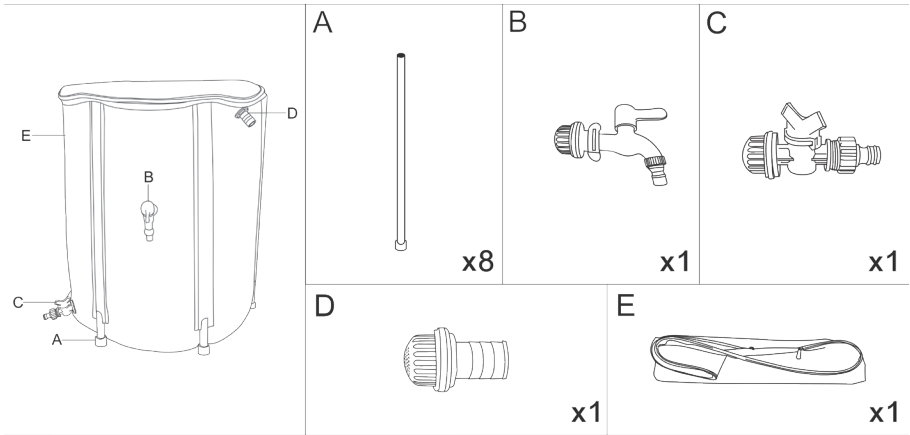

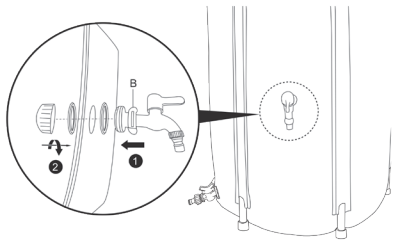
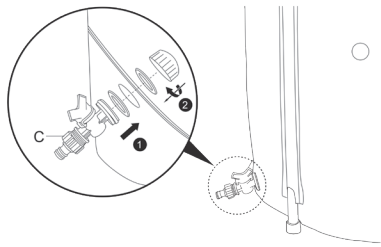

01  x1

02  x1



03  x1

04  x8  x1

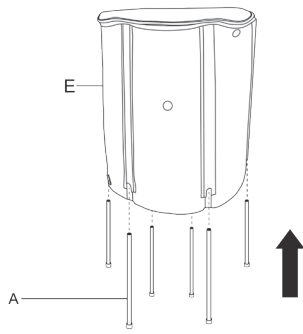
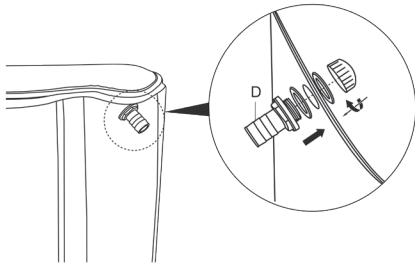

BEDIENUNGSANLEITUNG

MODE D'EMPLOI

ERKLÄRUNG DER ANSCHLÜSSE

EXPLICATION DES CONNEXIONS

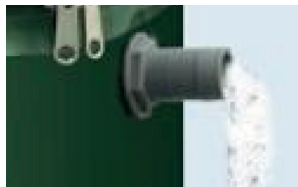

D Überlauf-Schutz / Protection anti-débordement

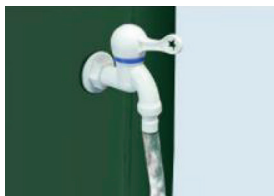

B Wasserhahn / Robinet



C Wasserablass / Vidange de l'eau



D Filter / Filtre

GARANTIE

- Das Produkt hat zwei Jahre Garantie ab Verkaufsdatum.
(Rechnung aufbewahren!)
- Schäden die von falschem Gebrauch herrühren fallen nicht unter die Garantiesprüche.
-

GARANTIE

- Votre produit a une garantie de deux ans à partir de la date d'achat.
(conservez la facture!)
- Les dommages résultant d'une mauvaise utilisation ne sont pas couverts par la garantie.